

GROUND FLOOR  
ELEV. A

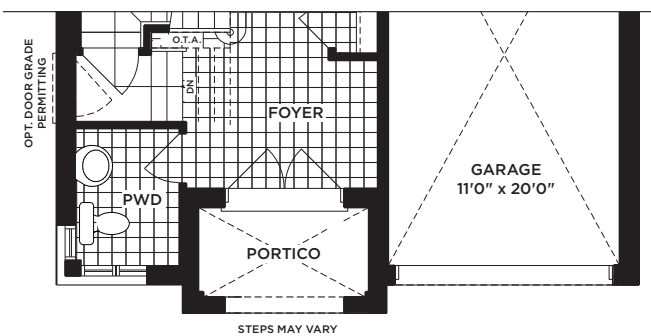

PART. GROUND FLOOR  
ELEV. C

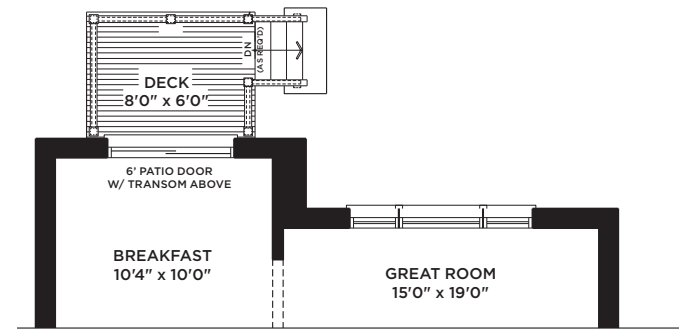

PART. GROUND FLOOR  
ELEV. A & C - L.O.D. CONDITION

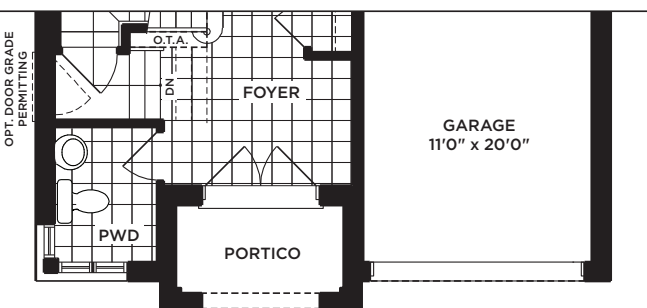

PART. GROUND FLOOR  
ELEV. D

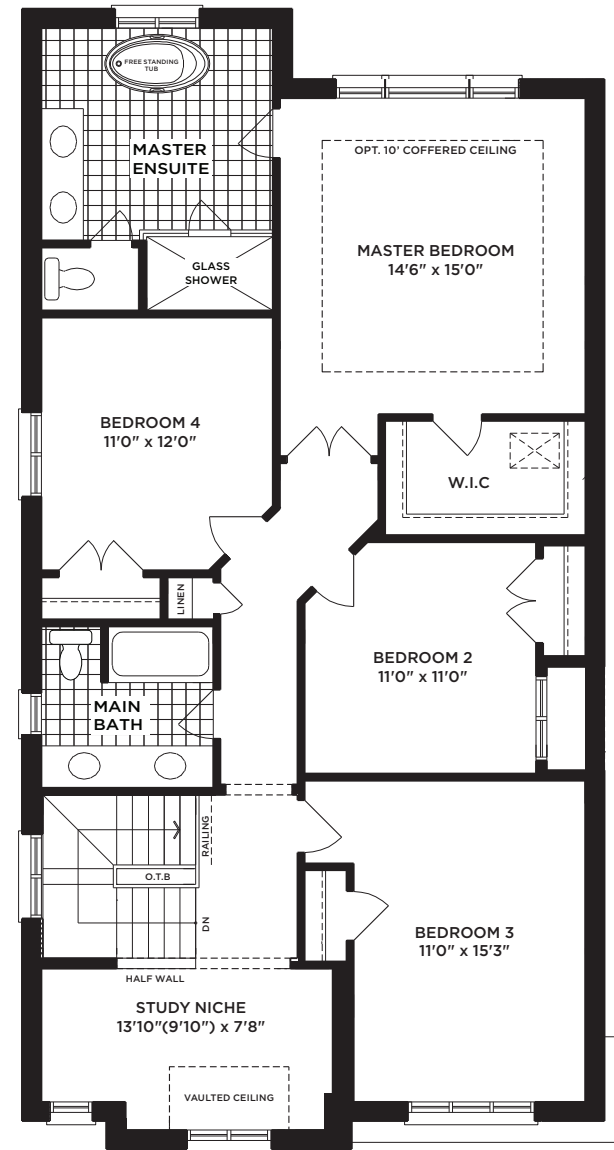

SECOND FLOOR  
ELEV. A

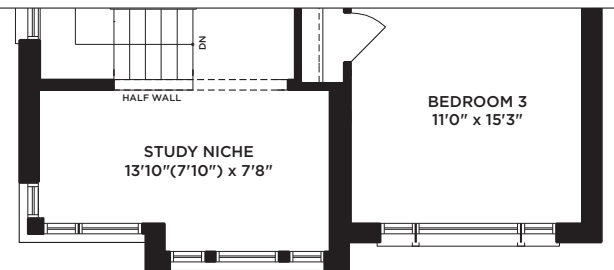

PART. SECOND FLOOR  
ELEV. C

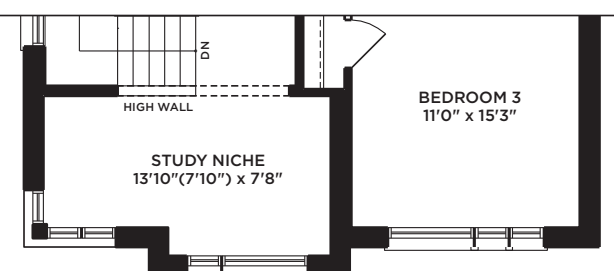

PART. SECOND FLOOR  
ELEV. D

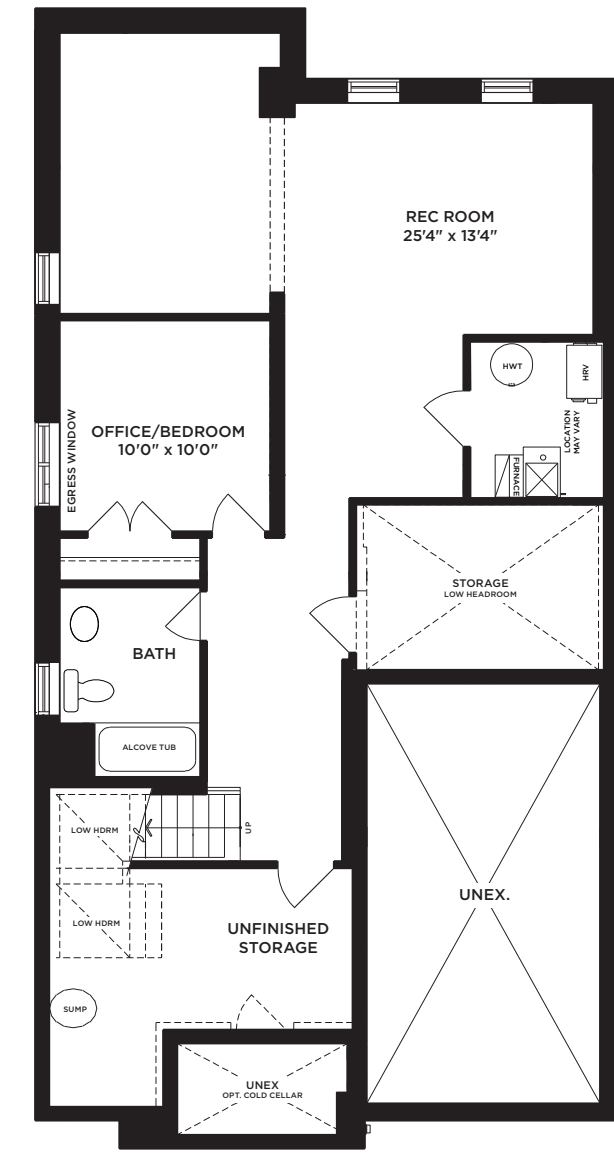

OPT. FINISHED BASEMENT  
ELEV. A (ELEV. C & D SIMILAR)

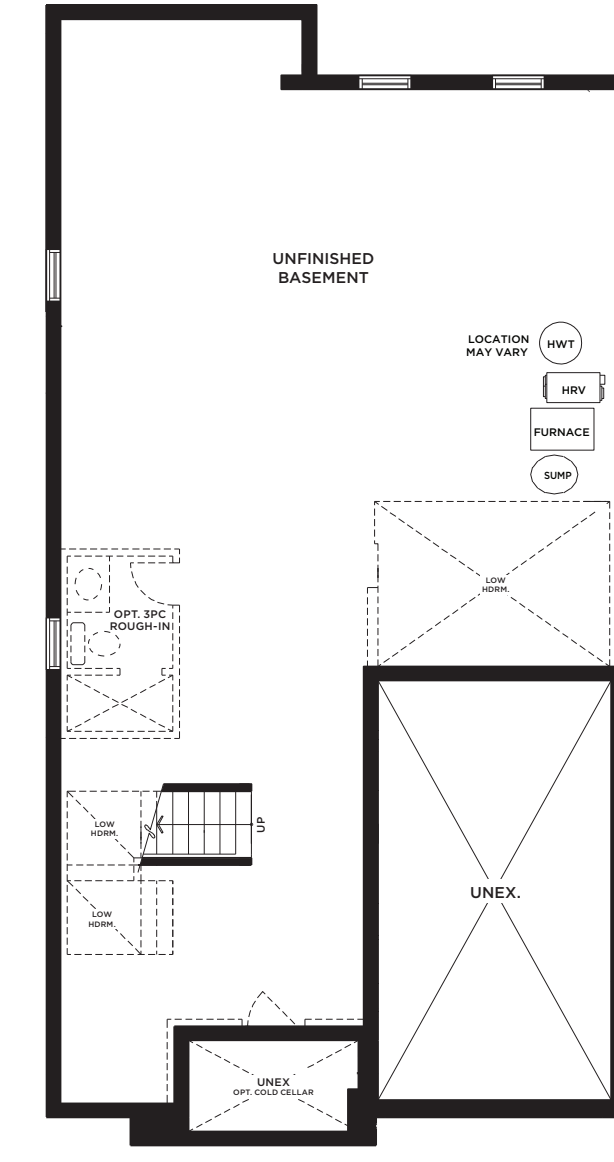

BASEMENT  
ELEV. A

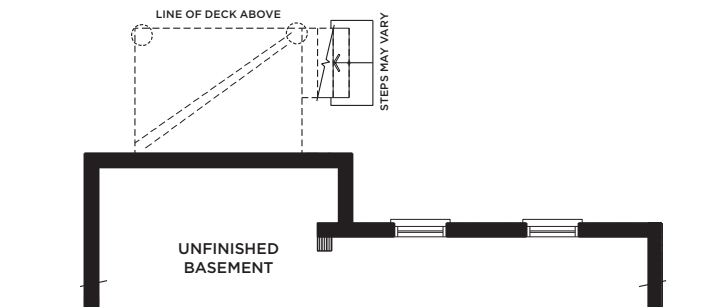

PART. BASEMENT  
ELEV. A & C - L.O.D. CONDITION

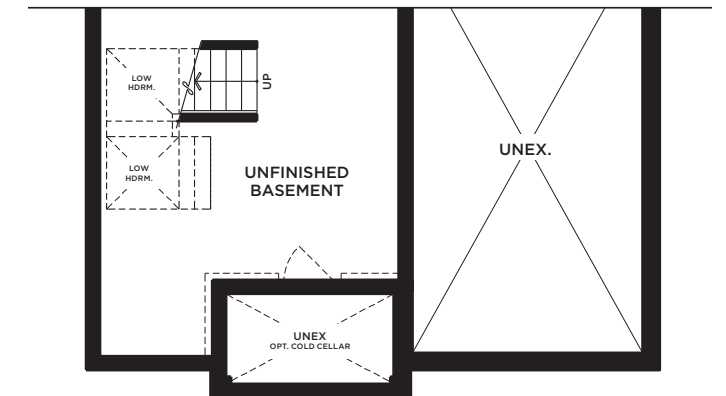

PART. BASEMENT  
ELEV. C (ELEV. D SIMILAR)

# THE BATEMAN

ELEV. C | 2,535 SQ. FT.  
ELEV. D | 2,535 SQ. FT.

Materials, specifications, and floor plans are subject to change without notice. Stair configurations, layout, and that all basement mechanical, rough-ins and sump location are subject to change without notice at the builders discretion. All renderings are artist concept. All floor plans are approximate dimensions. Front porches and stairs may require steps and/or railings pending final grading. Number of interior stair risers, winders and configuration subject to change without notice. Window sizing, configuration and spacing subject to change. Floor plans represent only one elevation and may be reversed subject to grading. Site may be subject to Architectural Control and therefore exterior elevations, including size, specifications, location of windows and material are subject to review and may change without notice. Actual usable floor space may vary from the stated floor area. Square footage includes open space. E. & O.E.